

Grace UL2014

Dimensions

Outside – 20" x 14"

Inside – 17 5/8" x 11 3/4"

- 8" depth
- A grade Vitreous china
- Overflow holes
- Available in white
- Limited 2 Year Warranty



COMPLIANCE CERTIFICATIONS

- Compliant with UPC, National Plumbing Code of Canada, IPC & IRC
- Compliant with ASME A112.19.2-2008/CSA B345.1-2008 Certification Standard
- Certificate of Listing filed with ICC Evaluation Service



Technical Information

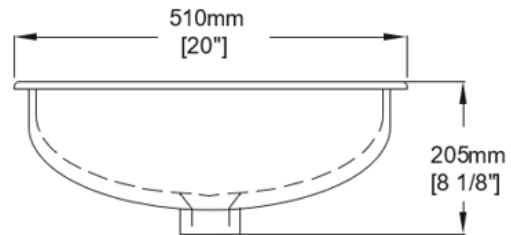
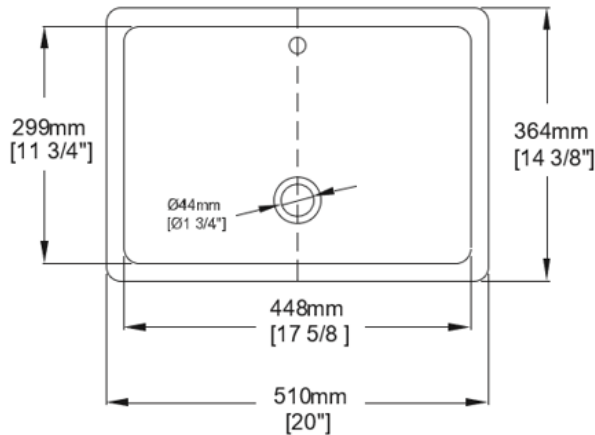

COUNTERTOP CUT-OUT:

- The cut-out template is provided as a **guide only** and should be checked against the actual sink to determine correct fit.
- It is recommended that **the hole for the sink be cut 1/2" x 1/2" smaller than the inside bowl dimensions.**

SINK DIMENSIONS • Diagrams not to scale. • All measurements ±1/4".

Model #	Description	Weight (lbs)	Shipping Dimensions	Cubic Feet
UL2014	Rectangle Sink	17.1		1.5