

Model : IT1A165E

Installation Manual

- Thank you for choosing our products. Please read the instructions carefully before installation and keep it available for future maintenance or reference.

Content

Installation

Safety instructions	01
Technical specification	05
List of materials	07
Technical drawing	08
FCC Statement	09
IC Statement	09
Parts identification	10
Toilet installation	11
Preparation	14
Auto open/close lid	15
Foot sensor	16

Maintenance

Maintenance	17
1. Main unit care and maintenance	
2. Filter maintenance	
3. Spray nozzle care and maintenance	
Emergency troubleshooting	18
1. Power and water failure	
2. Failure of remote control	
3. Product unused for a period of time	

Others

Main unit knob function instructions	19
Description of the top indicator lights	20
Troubleshooting guide	21

IMPORTANT SAFEGUARDS

When using electrical products, especially when children are present, basic safety precautions should always be followed, including the following:

1. The appliance is not to be used by persons (including children) with reduced physical, sensory or mental capabilities, or lack of experience and knowledge, unless they have been given supervision or instruction.
2. This appliance can be used by children aged from 8 years and above and persons with reduced physical, sensory or mental capabilities or lack of experience and knowledge if they have been given supervision or instruction concerning use of the appliance in a safe way and understand the hazards involved.
3. Children shall not play with the appliance.
4. Cleaning and user maintenance shall not be made by children without supervision.

READ ALL INSTRUCTIONS BEFORE USING



DANGER – To reduce the risk of electrocution:

1. Do not use while bathing.
2. Do not place or store product where it can fall or be pulled into a tub or sink.
3. Do not place in or drop into water or other liquid.
4. Do not reach for a product that has fallen into water. Unplug immediately.
5. Do not wash the main unit or electrical plug with water or detergent.
6. Do not handle the electrical plug with wet hands.
7. Never block the outlet of the air dryer.
8. Never disassemble, repair or modify this product.
9. During installation, disassembly, repair and maintenance of the product, the power plug must be switched off and water supply be shut off.



DANGER – Réduire le risque d'électrocution:

1. Ne pas utiliser pendant le bain.
2. Ne pas placer ou stocker le produit dans un endroit où il pourrait tomber ou être tiré dans une baignoire ou un évier.
3. Ne pas placer ou laisser tomber le produit dans l'eau ou tout autre liquide.
4. Ne tendez pas la main pour obtenir le produit tombé dans l'eau. Débranchez immédiatement la prise.
5. Ne lavez pas l'unité principale ou les prises électriques avec de l'eau ou des détergents.
6. Ne pas manipuler la prise électrique avec les mains mouillées.
7. Ne jamais obstruer la sortie du sècheur d'air.
8. Ne jamais démonter, réparer ou modifier ce produit.
9. À l'occasion de l'installation, du démontage, de la réparation et de l'entretien du produit, la prise de courant doit être coupée et l'alimentation en eau doit être interrompue.



WARNING – To reduce the risk of burns, electrocution, fire, or injury to persons.

1. Close supervision is necessary when this product is used by, on, or near children or individuals with disabilities.
2. Use this product only for its intended use as described in this manual. Do not use attachments not recommended by the manufacturer.

3. Never operate this product if it has a damaged cord or plug, if it is not working properly, if it has been dropped or damaged, or dropped into water. Return the product to a service center for examination and repair.
4. Keep the cord away from heated surfaces.
5. Never use while sleeping or drowsy.
6. Never drop or insert any object into any opening or hose.
7. Do not use outdoors or operate where aerosol (spray) products are being used or where oxygen is being administered.
8. Connect this product to a properly grounded outlet only. See Grounding Instructions.
9. Do not throw cigarettes and other burning materials into toilet, otherwise it might cause fire.
10. This product is an electric appliance, so it must be placed far away from water and other liquid.
11. Do not lay the product on its side or upside down during the electrical circuit.
12. It is prohibited to use other electric appliances in the same socket.
13. It is forbidden to use the power extension or unstable loose outlet.
14. Do not reuse any existing water supply hoses, otherwise it might cause leakage, fire or electrical shock. Installation should include specified components and a new water supply hose.



AVERTISSEMENT – *Pour réduire les risques de brûlure, d'électrocution, d'incendie ou de blessure.*

1. *Ce produit doit être surveillé de près lorsqu'il est utilisé par, sur ou à proximité d'enfants ou de personnes handicapées.*
2. *N'utilisez ce produit que pour l'usage auquel il est destiné, tel qu'il est décrit dans ce manuel. N'utilisez pas d'accessoires non recommandés par le fabricant.*
3. *N'utilisez jamais ce produit si le cordon ou la fiche est endommagé, ne fonctionne pas correctement, tombe ou est endommagé, ou tombe dans l'eau. Retourner le produit au centre de service pour inspection et réparation.*
4. *Gardez le cordon loin des surfaces chaudes.*
5. *Ne jamais utiliser pendant le sommeil ou la somnolence.*
6. *Ne laissez jamais tomber ou n'insérez jamais d'objet dans une ouverture ou un tuyau.*
7. *Ne pas utiliser à l'extérieur ou dans des endroits où des aérosols (sprays) ou de l'oxygène sont utilisés.*
8. *Connectez ce produit uniquement aux prises correctement mises à la terre. Voir les instructions de mise à la terre.*
9. *Ne jetez pas de cigarettes et autres substances brûlées dans les toilettes, sinon cela pourrait provoquer un incendie.*
10. *Ce produit est un appareil électrique et doit donc être placé loin de l'eau et d'autres liquides.*
11. *Dans le circuit, ne pas allonger le produit sur le côté ou à l'envers.*
12. *L'utilisation d'autres appareils électriques dans la même prise est interdite.*
13. *Il est interdit d'utiliser des rallonges d'alimentation ou des prises lâches instables.*
14. *Ne réutilisez pas les tuyaux d'alimentation existants, car ils pourraient provoquer une fuite, un incendie ou une électrocution. L'installation doit inclure les composants spécifiés et un nouveau tuyau d'alimentation en eau.*

IMPORTANT SAFETY INSTRUCTIONS



CAUTION – Indicates that failure to follow the instruction may cause body injury or property damage.

1. Do not install or use the product in wet places as steam room etc.
2. It is recommended to use water-proof electrical outlet which should be installed in a place where is not easily to get wet.
3. This product should be used with 110V-120V, 50-60Hz electrical current only, load current is at least 15A. Power plug must be equipped with ground fault circuit interrupter or ground fault electrical leakage protector or similar high sensitive, rapid type leakage switch (Rated sensitive current under 6mA).
4. When it thunders, it is strongly recommended to pull out the power plug.
5. Do not stand on ceramic toilet.
6. Ceramic toilet must install floor fixing bolts.
7. Do not stand on product unit, seat and lid.
8. Do not lean against the seat lid when using the product, to avoid damage.
9. This product is equipped with a soft-closing seat lid. Do not push the toilet seat closed, or damage may occur.
10. Do not use any caustic chemicals or scrubbing brush to clean this product.
11. Exposure to direct sunlight is prohibited.
12. Only use tap water or potable water, otherwise it may cause chafing.
13. Do not connect water supply to heater outlet. Make sure inlet water temperature is between 3~35°C/37.4~95°F.
14. When the room temperature is under zero degree, please drain the water tank, to avoid freezing.
15. Raise room temperature to prevent the toilet from damage due to freezing.
16. When moving the product from cold or wet environment into normal room temperature, wait for 2 hours until the condensation water is fully volatilized. Doing so can prevent the product from electrical short-circuit.
17. When not using the product over three(3) days, drain the water out of the toilet and pull the electrical plug from the wall outlet.
18. Stop using the product and shut off the power when product malfunctions. Call for professional service.



ATTENTION – *Indique que le non-respect de l'instruction peut entraîner des blessures corporelles ou des dommages matériels.*

1. *N'installez pas ou n'utilisez pas le produit dans un endroit humide, tel qu'une chambre à vapeur, etc.*
2. *Il est recommandé d'utiliser une prise de courant étanche, qui doit être installée dans un endroit où elle ne risque pas d'être mouillée.*
3. *Ce produit doit être utilisé avec un courant électrique de 110V-120V, 50-60Hz uniquement, le courant de charge étant d'au moins 15A. La fiche d'alimentation doit être munie d'un disjoncteur de défaut de mise à la terre ou d'un protecteur de fuite de défaut de mise à la terre ou d'un interrupteur de fuite de type rapide de haute sensibilité similaire (courant sensible nominal inférieur à 6 ma).*
4. *En cas de tonnerre, il est fortement recommandé de débrancher la prise électrique.*
5. *Ne vous tenez pas debout sur les toilettes en céramique.*
6. *Les toilettes en céramique doivent être équipées de boulons de fixation au sol.*
7. *Ne pas se tenir debout sur l'unité de produit, le siège et le couvercle.*
8. *Ne vous appuyez pas sur le couvercle du siège lorsque vous utilisez le produit, afin d'éviter de l'endommager.*
9. *Le produit est équipé d'un couvercle de siège à fermeture douce. Ne fermez pas le siège de toilette, il pourrait causer des dommages.*

10. *N'utilisez pas de produits chimiques agressifs ou de brosses pour nettoyer ce produit.*
11. *L'exposition directe au soleil est interdite.*
12. *Utilisez uniquement de l'eau du robinet ou de l'eau potable, sinon vous risquez de causer des éraflures.*
13. *Ne raccordez pas l'alimentation en eau à la sortie de l'appareil de chauffage. S'assurer que la température de l'eau d'entrée est comprise entre 3~35°C/37.4~95°F.*
14. *Lorsque la température ambiante est inférieure à zéro degré, veuillez vidanger le réservoir d'eau afin d'éviter le gel.*
15. *Augmentez la température de la pièce pour éviter que les toilettes ne soient endommagées par le givrage.*
16. *Lorsque le produit passe d'un environnement froid ou humide à une température ambiante normale, attendre 2 heures jusqu'à ce que l'eau de condensation soit entièrement volatilisée. Ce faisant, vous évitez les courts - circuits électriques du produit.*
17. *Lorsque le produit n'est pas utilisé pendant plus de trois (3) jours, videz l'eau des toilettes et débranchez la prise électrique de la prise murale.*
18. *Cessez d'utiliser le produit et éteignez l'alimentation lorsque le produit tombe en panne. Appel à un service professionnel.*

GROUNDING INSTRUCTIONS

This product should be grounded. In the event of an electrical short circuit, grounding reduces the risk of electric shock by providing an escape wire for the electric current. This product is equipped with a cord having a grounding wire with a grounding plug. The plug must be plugged into an outlet that is properly installed and grounded.



DANGER – Improper use of the grounding plug can result in a risk of electric shock.

If repair or replacement of the cord or plug is necessary, do not connect the grounding wire to either flat blade terminal. The wire with insulation having an outer surface that is green with or without yellow stripes is the grounding wire.

This product is factory equipped with a specific electric cord and plug to permit connection to a proper electric circuit. Make sure that the product is connected to an outlet having the same configuration as the plug. No adapter should be used with this product. Do not modify the plug provided — if it will not fit the outlet, have the proper outlet installed by a qualified electrician. If the product must be reconnected for use on a different type of electric circuit, the reconnection should be made by qualified service personnel.



DANGER - une mauvaise utilisation de la prise de terre peut entraîner un risque d'électrocution.

Si vous avez besoin de réparer ou de remplacer un fil ou une fiche, ne connectez pas le câble de mise à la terre à une borne de type lame plate. Les fils avec une couche isolante dont la surface extérieure est verte et avec ou sans bandes jaunes sont des fils de terre.

Ce produit est équipé en usine d'un cordon électrique et d'une fiche spécifiques permettant de le connecter à un circuit électrique approprié. Assurez-vous que le produit est branché sur une prise ayant la même configuration que la fiche. Aucun adaptateur ne doit être utilisé pour ce produit. Ne modifiez pas la fiche fournie — si elle n'est pas adaptée à la prise, faites installer la prise adéquate par un électricien qualifié. Si le produit doit être reconnecté pour être utilisé sur un autre type de circuit, il doit être reconnecté par un personnel de service qualifié.

SAVE THESE INSTRUCTIONS

Technical specification

Model		U59-T
Main Unit	Rated voltage	110V-120V, 50Hz-60Hz
	Rated power	875W
	Water proof	IPX4
	Power cord length	About 1.5m
Toilet	Flush volume	1.6/1.1Gpf, 6.0L(full flush)/4.1L(half flush)
	Flushing mode	Siphonic jet
	Rough-in	12 inches (305mm)
	Outlet outside diameter	≤ 3.9 inches (≤ 100mm)
	Drainage method	S-trap
	Water pressure range	Minimum water pressure 0.08MPa, Maximum water pressure 0.8MPa
Cleaning device	Heating mode	Instant
	Heating power	120V/1400W
	Water temperature	6-level adjustment
	Water volume	3-level adjustment
	Cleaning mode	Rear washing/Oscillating washing, Front washing/Oscillating washing
	Nozzle position	5-level adjustment
	Water pressure protector	Pressure maintaining device, Automatic pressure relief device
	Anti-fouling device	Automatic nozzle cleaning, Anti-backflow device, Anti-syphon device, Filter device
	Safety device	Thermal fuse, Ground protection, Thermostat, Water temperature sensor, Over temperature protection, Leakage protection plug
Deodorization	Deodorization method	Photocatalyst-free

Drying device	Warm air volume	Over 0.2m ³ /min
	Warm air temperature	6-level adjustment
	Heating power	230W
	Warm air speed	3-level adjustment
	Safety device	Thermal fuse, Thermostat, Leakage protection plug, Wind temperature sensor
Heated seat	Surface temperature	6-level adjustment
	Heating power	50W
	Burn protection	After 10 minutes of use, the seat temperature will automatically drop slowly to a low level
	Safety device	Seat sensor, Temperature sensor, Thermostat, Thermal fuse, Leakage protection plug
Caring device	Night light assembly	Intelligent, Always on, Always off
	User ID setting	To avoid interference when used by multiple users
	Automatic flushing	Automatic flushing after use
	Foam Shield function	Splash-proof and odor-proof can be realized
	Foot sensor open lid	Foot sensor open lid/seat can be realized
	Foot sensor flushing function	Foot sensor flushing
	Auto-open lid function	Auto-open lid function can be realized
Antibacterial site		Seat, Nozzle

Rated power: Under the condition of ambient temperature 23°C/73°F, water static pressure 0.18MPa±0.02MPa, water temperature 15°C/59°F, power toilet on, set water pressure, seat temperature, water temperature to the highest level in turn and perform one rear washing cycle.

FCC Statement

This device complies with Part 15 of the FCC Rules. Operation is subject to the following two conditions: (1) This device may not cause harmful interference, and (2) this device must accept any interference received, including interference that may cause undesired operation.

NOTE: This equipment has been tested and found to comply with the limits for a Class B digital device, pursuant to Part 15 of the FCC Rules. These limits are designed to provide reasonable protection against harmful interference in a residential installation. This equipment generates uses and can radiate radio frequency energy and, if not installed and used in accordance with the instructions, may cause harmful interference to radio communications. However, there is no guarantee that interference will not occur in a particular installation. If this equipment does cause harmful interference to radio or television reception, which can be determined by turning the equipment off and on, the user is encouraged to try to correct the interference by one of the following measures:

- Reorient or relocate the receiving antenna.
- Increase the separation between the equipment and receiver.
- Connect the equipment into an outlet on a circuit different from that to which the receiver is connected.
- Consult the dealer or an experienced radio/TV technician for help.

WARNING: Any changes or modifications not expressly approved by the party responsible for compliance could void the user's authority to operate this equipment.

The device must not be co-located or operating in conjunction with any other antenna or transmitter.

FCC RF Radiation Exposure Statement Caution: To maintain compliance with the FCC's RF exposure guidelines, place the product at least 20cm from nearby persons.

IC Statement

This device complies with Industry Canada license-exempt RSS standard(s). Operation is subject to the following two conditions: (1) this device may not cause interference, and (2) this device must accept any interference, including interference that may cause undesired operation of the device.

Le présent appareil est conforme aux CNR d'Industrie Canada applicables aux appareils radio exempts de licence. L'exploitation est autorisée aux deux conditions suivantes : (1) l'appareil ne doit pas produire de brouillage, et (2) l'utilisateur de l'appareil doit accepter tout brouillage radioélectrique subi, même si le brouillage est susceptible d'en compromettre le fonctionnement.

This equipment should be installed and operated with minimum distance 20cm between the radiator & your body.

Cet équipement doit être installé et utilisé avec un minimum de 20 cm de distance entre la source de rayonnement et votre corps.

CAN ICES-003(B) / NMB-003(B).



List of materials

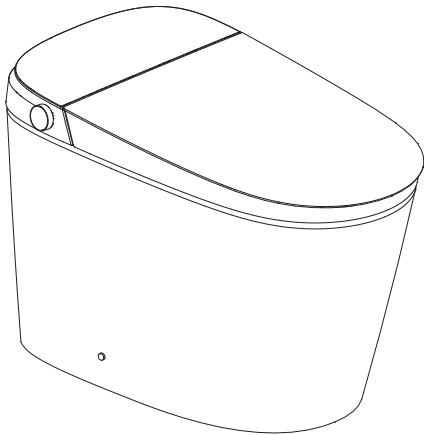

Main Unit



Remote Control Components

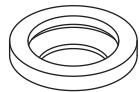

Sealing Flange



Rough-in Template

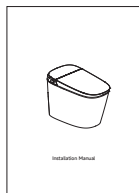

Installation Manual



Filling funnel

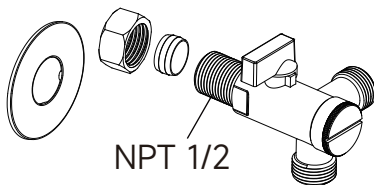

Three way angle valve

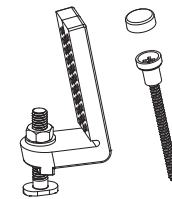

Mounting Kit

Technical drawing

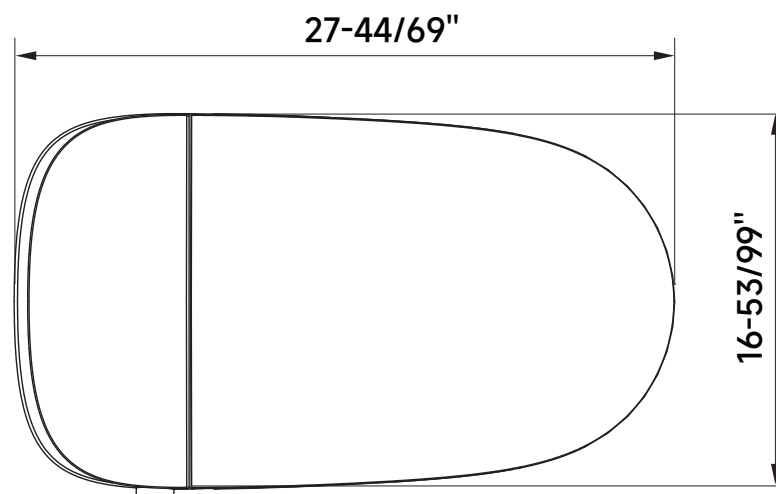
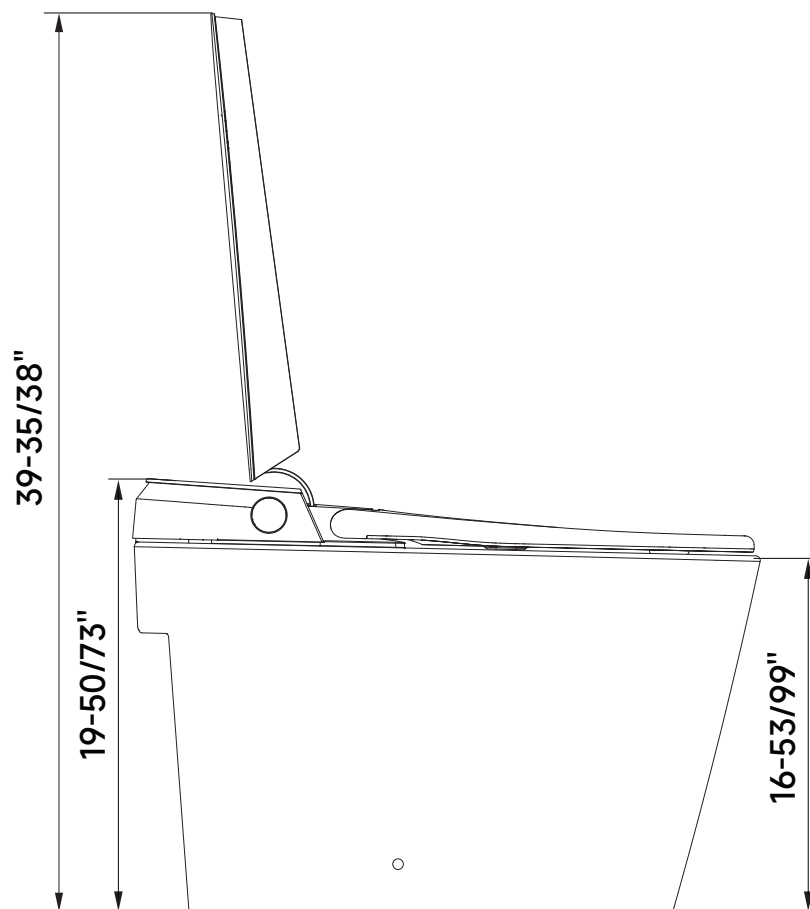

1. The drawing is for reference only, and we reserve the right to modify the product appearance.
2. Product appearance is subject to change in kind.



Parts identification

Left side

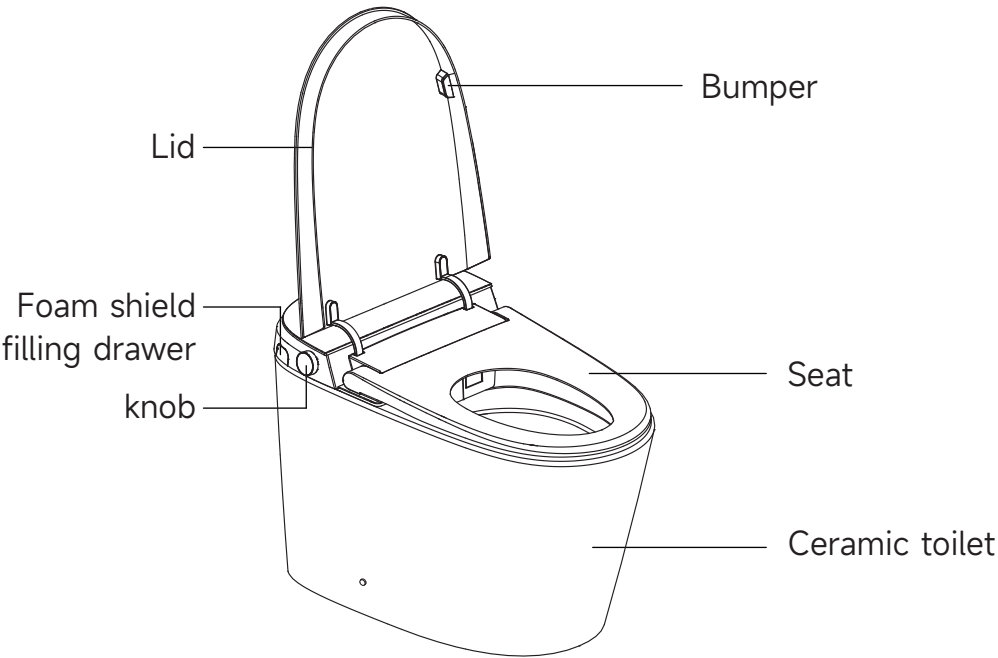

Right side

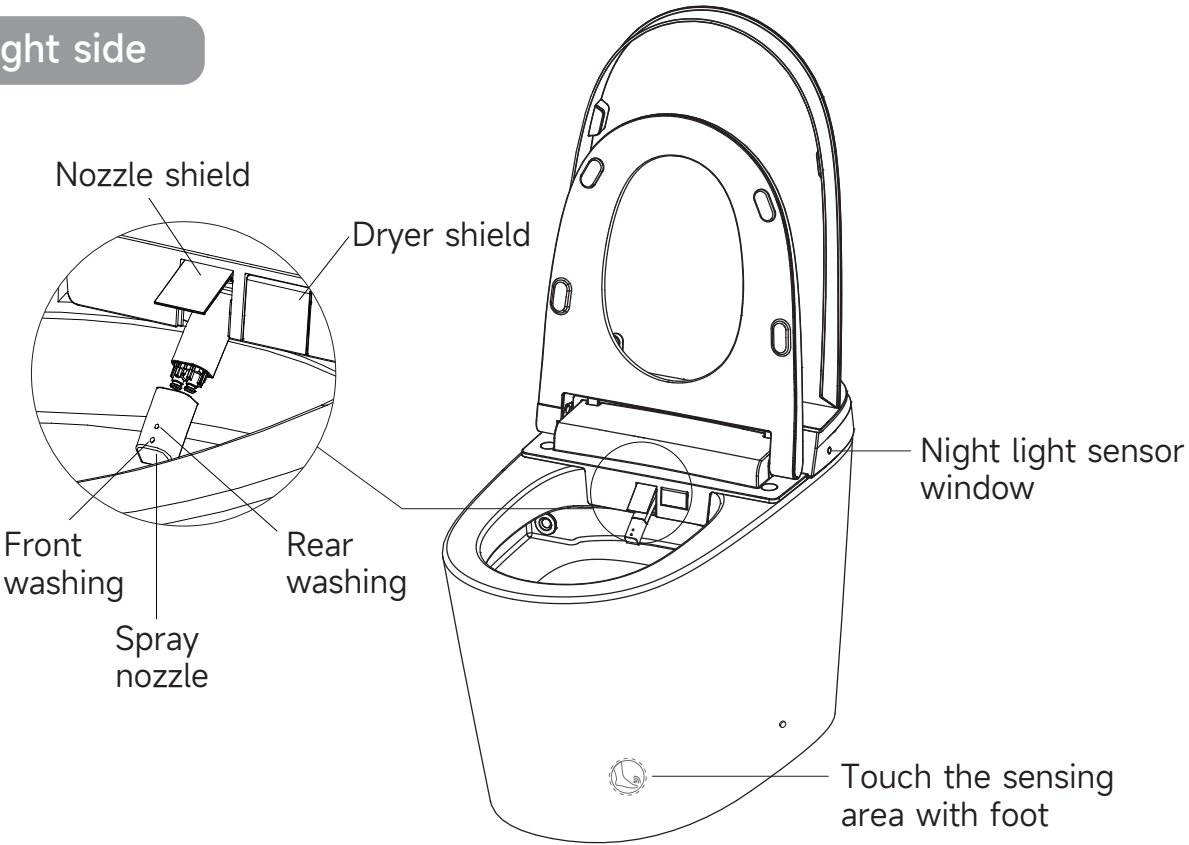

Toilet installation

1. Install the matching three-way angle valve

- Mark the center line of the sewage outlet on the ground, and install a three-way angle valve at a suitable position on the wall according to the size of the toilet.

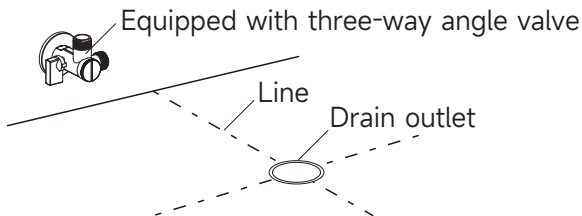

Note:

1. Please use the supplied angle valve when installing this toilet. Use of another angle valve not including a filter may result in blockages in the toilet and bidet waterways.
2. If replacing an existing angle valve, please contact a professional for installation.

Installation Method 1:

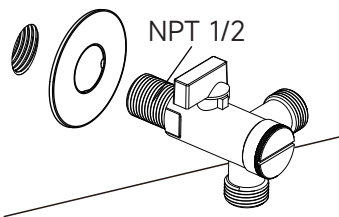

Installation Method 2:

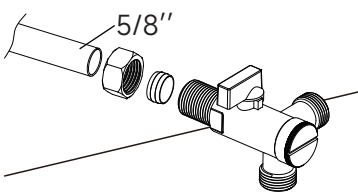

2. Rough-in template installation

- Align cardboard with the centerline of drain outlet.
- Draw contour line according to cardboard.

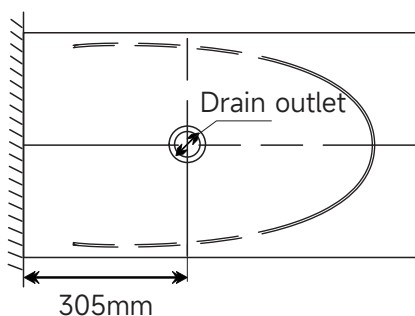

3. Mounting bracket installation

- Assemble the mounting bracket with bolts and then install them to the pre-installed flange plate on the ground and lock tight with nuts.

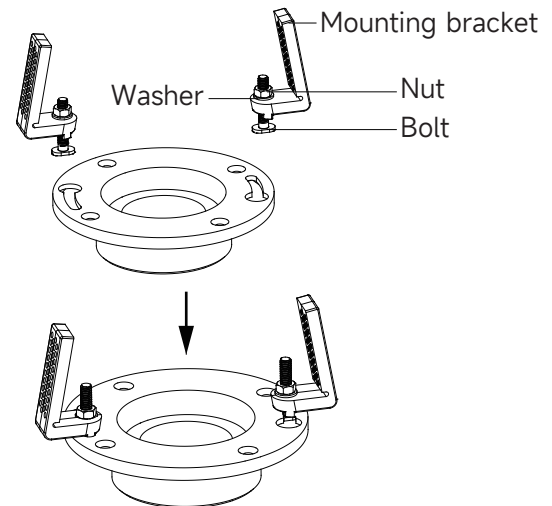

4. Ceramic toilet installation

- Install a sealing flange into drain outlet.
- Install ceramic toilet on the corresponding position.

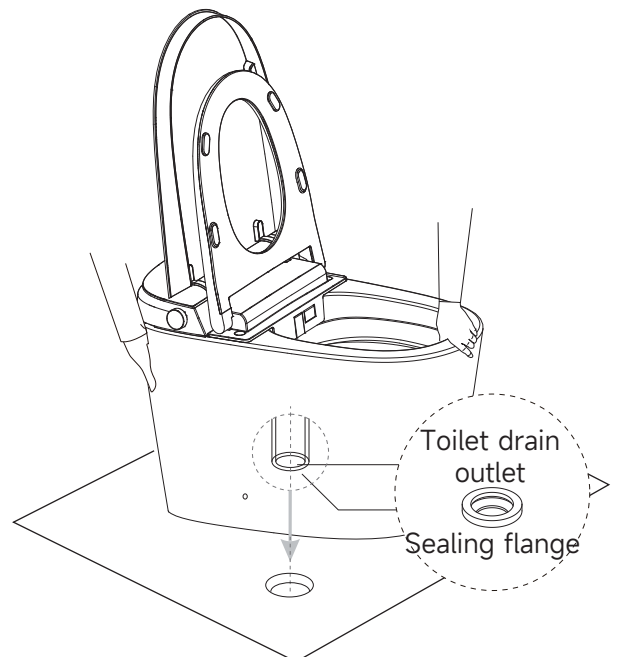

Note:

1. Two people are required to carry the toilet.
2. Please clean up the drain outlet.
3. Please make sure ceramic toilet outlet sits perfectly on drain outlet.

5. Screw installation

- Put the screw through the fixing sleeve and then install it through the holes (on both sides of the toilet bowl) to the mounting bracket on the ground. Lock tight.
- Install the decorative cap on the fixing sleeve.

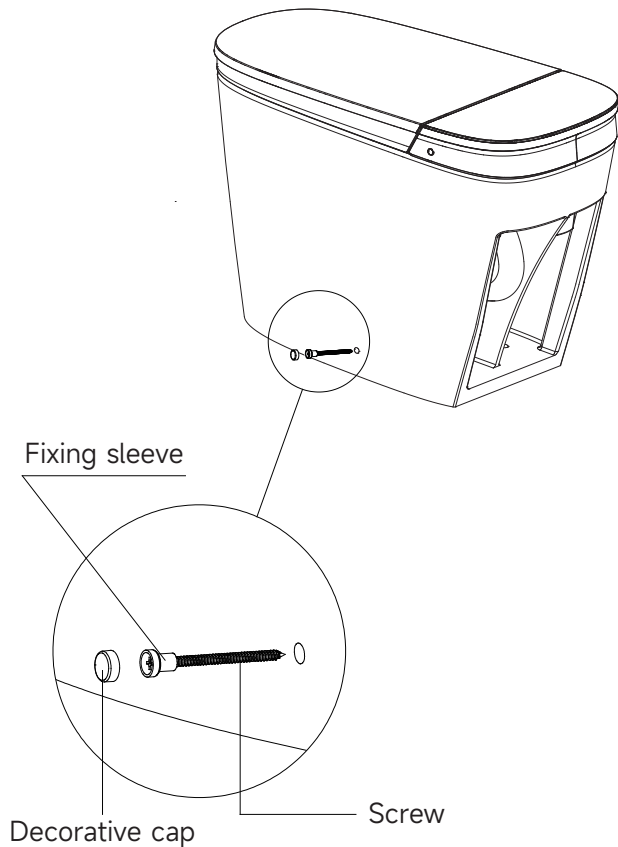

6. Connect the hoses

- Connect the water supply hose of the toilet tank and the water inlet hose of the toilet seat to the three-way angle valve as shown in the figure.

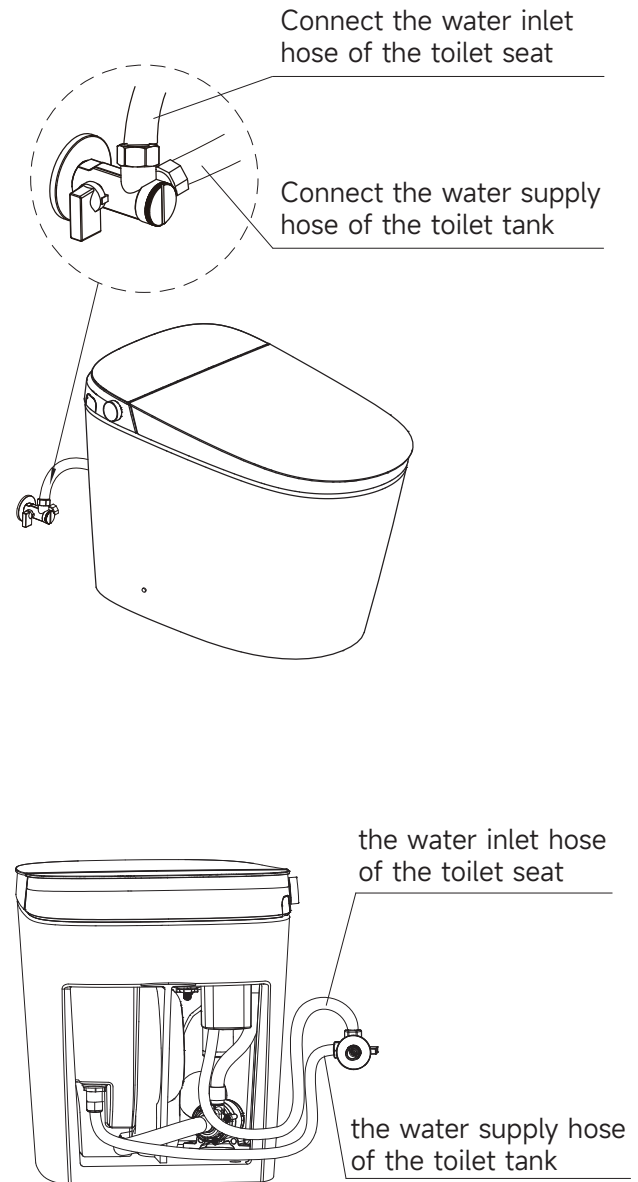

7. Add foam agent (Please buy from local store)

- Use your fingers or tools to reach under the filling box and pull out the filling box. (it is recommended to use a filling funnel, as shown below)

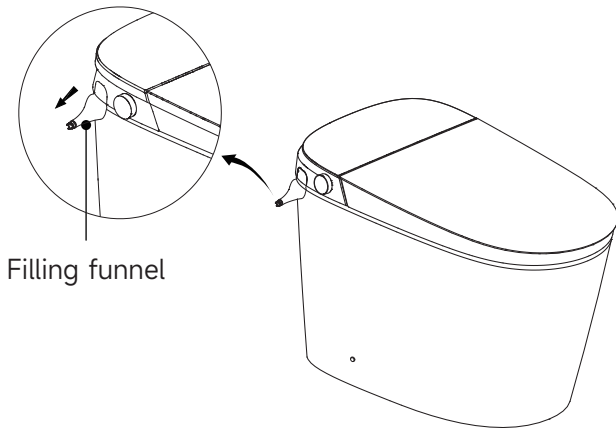

- Put the funnel into the filling port, hold it, and slowly pour the foam liquid into the funnel with the other hand. (Do not quickly pour the foam liquid into the funnel to avoid the foam liquid overflowing)

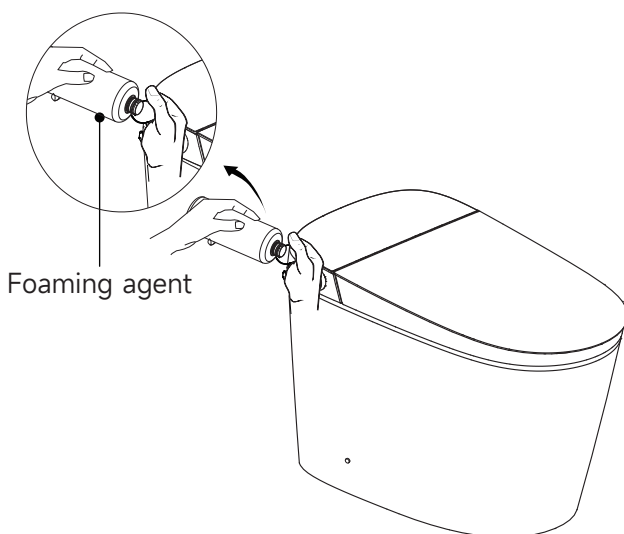

- Close the sealing cap and press tightly, then push the filling drawer to the end. (If the foam liquid overflows during the liquid addition process, use a paper to dry the liquid before pushing it in)

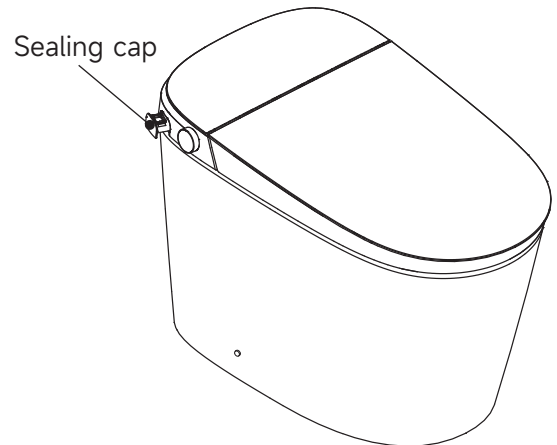

Reminder:

In order to achieve the best effect and prolong the service life of the foam shield, please use our special foam agent for smart toilets

Preparation

1. Turn on the three-way angle valve

- Check the threaded connection for leaks to ensure complete sealing. Turn the three-way angle valve counterclockwise to the full open position.
(Note: The three-way angle valve opens with a large torque for the first time.)

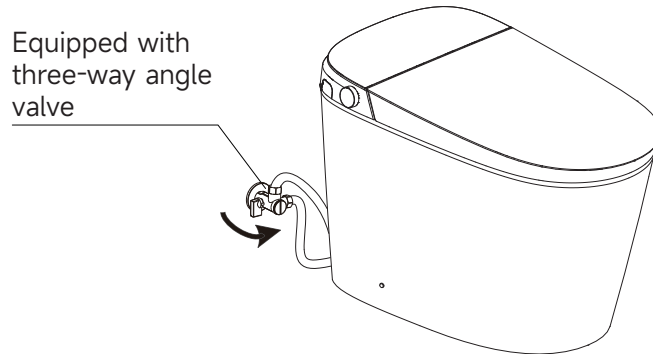

2. Power Connection

- Plug in the leakage protection plug to a power socket, press the reset switch, plug indicator lights up, indicating that the power is on.

Note:

Press the test button prior to usage, the reset switch pops up indicating that the leakage protection function is normal.

Press the TEST button (then RESET button) every month to assure proper operation.

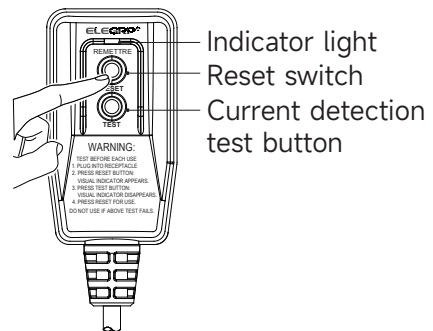

- * Only for models with leakage protection plug.
- * Please refer to the actual product.

3. Self-inspection

- The buzzer of the main unit makes a beep, the indicator light of the function icon and the light of the knob are on, and the self-test starts.
- The buzzer of the main unit beeps again, and the self-test is completed, and the indicator lights of the function icons and the knob lights work as normal.
- The function mode is turned on and used normally.

4. Activate the Foam shield function

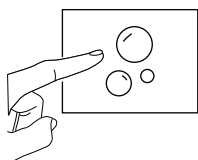

Long press "FOAM CLEANER" button on the remote control until the foam comes out and then release it to complete the "pumping" action

- Before starting the foam shield for the first time, the foam agent needs to be pumped into the foam shield by using the "pump liquid" command.

Tips:

1. After executing the "pumping liquid" command, there may be a large amount of foam when using the foam shield for the first time, which is a normal phenomenon.
2. This operation is only used when the toilet is just installed or when the foam agent is used up to replace the foam agent, and the use of the rest of the time will cause foam agent waste.

Auto open/close lid

The intelligent toilet can achieve the function of auto lid open/close. On closed situation, so please function the auto lid open/close function by using remote controller.

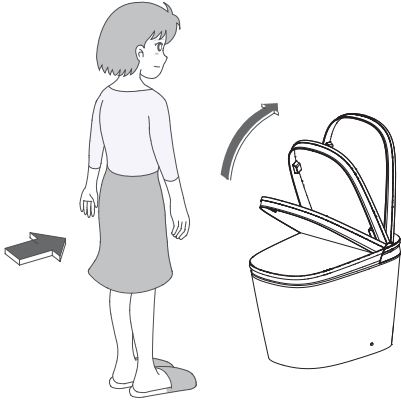

1. Approaching the toilet

When user enters the sensing range, the seat lid opens automatically.

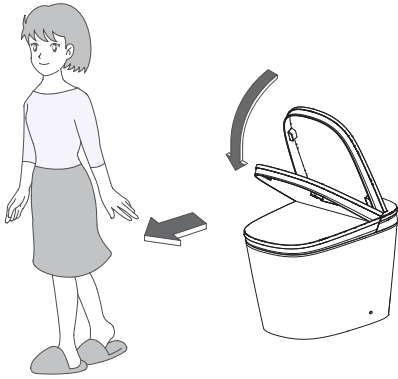

2. Leaving the toilet

The seat lid closes automatically after user leaves 180 seconds (3 minutes).

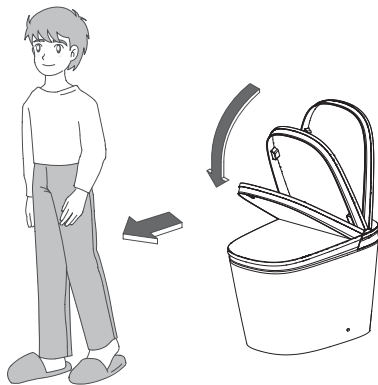

3. Standing up to urinate

1. Open the seat by remote control or hand.
2. The seat lid closes automatically after user leaves 180 seconds (3 minutes).

Foot sensor

The toilet is equipped with foot sensor lid-open function, it can make lid auto-open by sensing foot movement.

1. When the lid and seat are both closed, touch the sensing area with foot to open the lid.

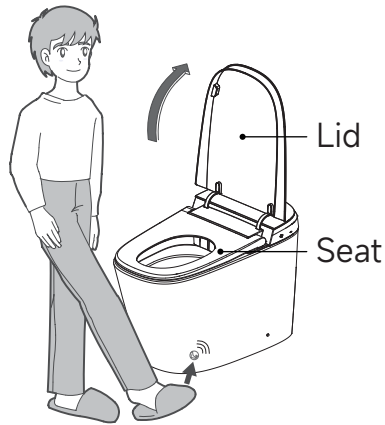

2. When the lid is open and seat closed, touch the sensing area with foot to open the seat.

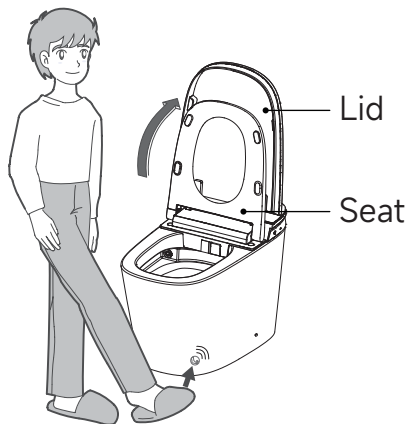

3. When the seat and lid are open, touch the sensing area with foot to close the seat and lid and activate a half flush.



Maintenance

Main unit care and maintenance

1. Shut off power supply before doing maintenance.
2. Use only a soft, damp cloth to clean. Avoid using harsh chemicals.

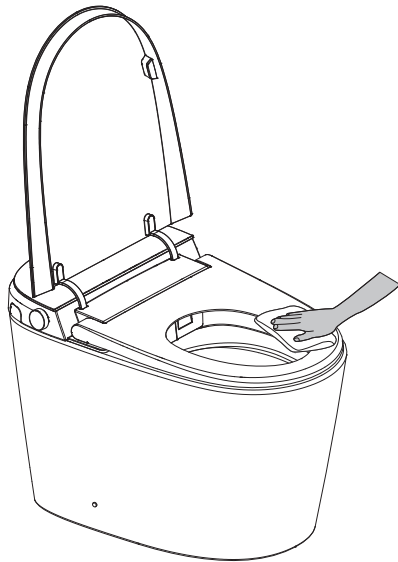

3. Once cleaning is completed and all surfaces are dry, re-connect the power plug.

Filter maintenance

If poor spray performance occurs under normal conditions:

1. Turn off power and the angle valve
2. Unscrew angle valve nut
3. Remove filter net

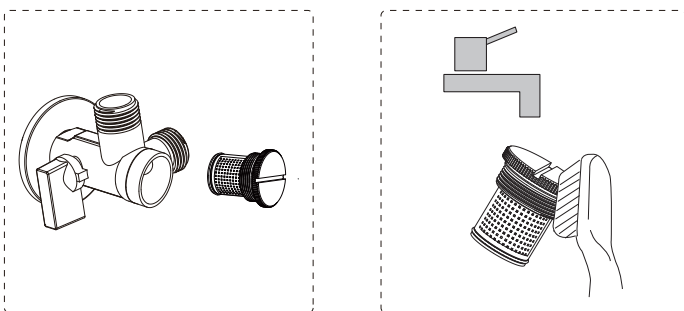

4. Clean out the filter net under running water using a toothbrush
5. Reinstall filter net and angle valve nut
6. Turn on the angle valve and connect the power.

Spray nozzle care and maintenance

1. When no one is seated, turn the knob clockwise. The nozzle will automatically stretch out to allow access for cleaning.
2. When the nozzle moves forward, the nozzle can be removed and cleaned separately.

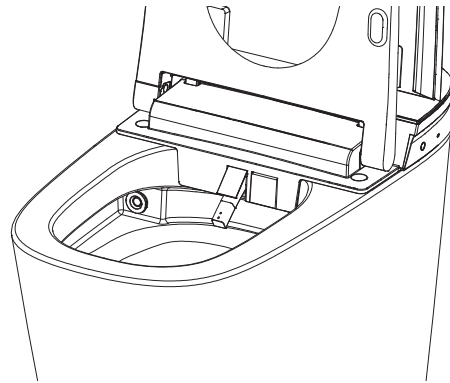

3. Use only a soft cloth or soft brush to clean. Do not pull or push the wand, to avoid damage.

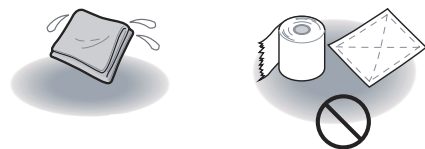

4. Put the nozzle back and press the knob to return the spray wand to its normal position.

Emergency troubleshooting

Power and water failure

- Fill up 2.1Gal (8L) water to a bucket and flush the ceramic bowl.

Note: Avoid water spilling from bowl.

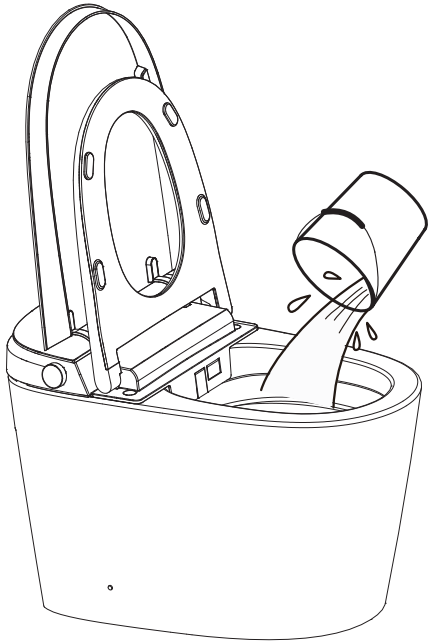

Failure of remote control

1. Operate via knob on the main unit.

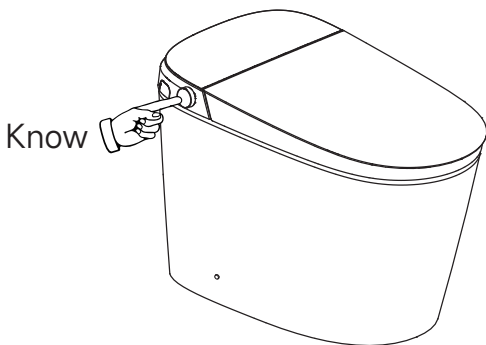

2. Battery replacement

- Remove the remote control from holder.
- Open the battery cover and replace the batteries.
- Put the remote control back.

Note:

After battery replacement, the remote control settings will be restored to the defaults.

Product unused for a period of time

- When the product is left unused for a long time, especially in cold weather, it is highly recommended to drain the water to prevent freezing.

To discharge water

1. Activate flushing, and then turn off angle valve to stop water supply.

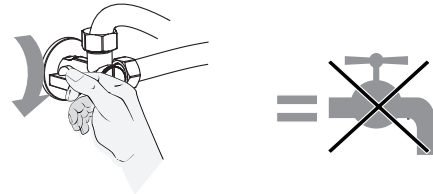

2. Unplug and disconnect from electricity.
3. Disconnect the hose from angle valve, drain the water and reconnect.

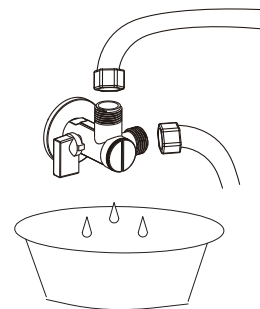

4. For your safety, it is recommended to put antifreeze into the remaining water in the bowl.

Note:

Please turn on power and water supply when using again.



Note: Before water discharging, the power must be cut off!

The main unit rotation function description

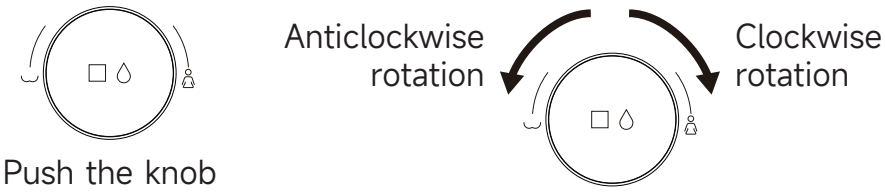

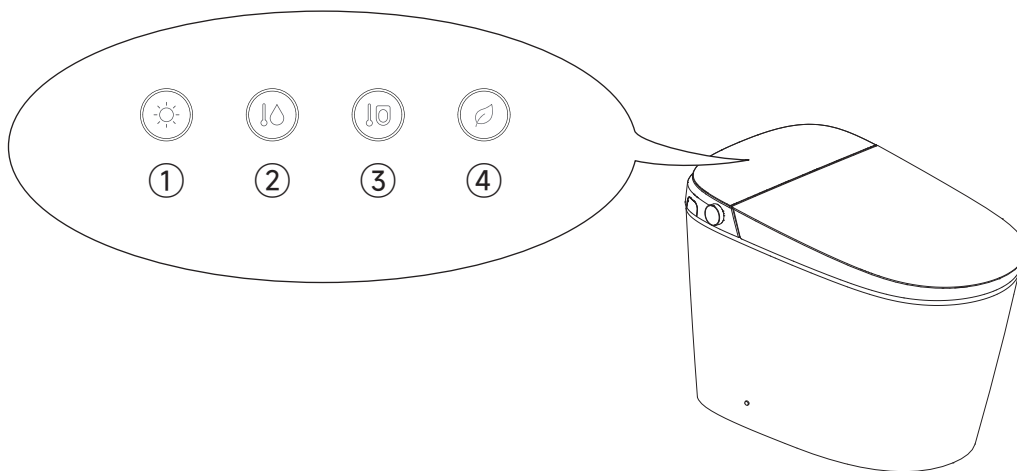

<div style="text-align: center;">Knob definition</div> <div style="text-align: center;">Knob function</div>		Knob indicator
Rear wash/ front wash	<p>In the seated state, turn the knob clockwise to start the feminine wash function, and turn it counterclockwise to start the rear wash function. After the first cleaning function (rear wash /front wash) is completed or short press the knob during the cleaning function, the warm air function and flushing function will be automatically activated.</p> <p>In the same seating situation, after using the knob to start the cleaning function again, short press the knob during the cleaning function, the warm air function will be automatically started, and the flushing function will not be turned on.</p>	
Nozzle position adjustment and cleaning water pressure adjustment	<p>When rear/front washing, turn the knob clockwise to move the nozzle position forward, and turn the knob counterclockwise to move the nozzle position backward.</p> <p>Long press the knob to switch to water pressure adjustment, turn clockwise to increase the water pressure, counterclockwise to decrease the water pressure, long press the knob again to switch to nozzle position adjustment.</p>	
Air flow temperature and air flow speed adjustment	<p>In the warm air state, turn the knob clockwise to increase the air temperature level, and turn the knob counterclockwise to decrease the air temperature level; for mobile dryer models, press and hold the knob button to switch to the air flow speed adjustment function, and then turn the knob clockwise. The air flow speed increases, and the air flow speed decreases when it is rotated counterclockwise; short press the knob to stop the warm air function. (Note: In the drying function state, the mobile dryer model can switch between the air flow speed adjustment and air temperature adjustment functions by long pressing the knob)</p>	White
Nozzle cleaning	<p>In the state of leaving the seat, turn the knob clockwise to start the nozzle manual cleaning function; short press the knob to stop the manual cleaning function, and the nozzle retracts.</p>	
Flush function	<p>In normal working mode, when there is no cleaning, drying or nozzle cleaning function, shortly press the knob to start the flushing function.</p>	
Operating mode	<p>In standby mode, press the knob to enter normal working mode.</p>	
Standby mode	<p>In normal working mode, when leaving the seat, press and hold the knob, the main unit enters standby mode, all functions are turned off, and the indicator light goes out.</p>	Turn off

Reminder: Just after starting up, defaulted level-1 for air speed of mobile drying, and middle-level for other functions; if you use the remote control, it will switch to the function gear set by the remote control.

Description of the top indicator lights



The power-on self-test is completed.

- ①  Intelligent night light: When the intelligent night light state is turned on, the night light indicator light is on, otherwise it is off.
- ②  Water temperature: The indicator light is on when the water temperature is in the 1-5 level, and the indicator light is off in the room temperature.
- ③  Seat temperature: The indicator light is on when the seat temperature is in the 1-5 level, and the indicator light is off in the room temperature.
- ④  Energy saving: The indicator light is on when the main unit is in power saving mode, otherwise it is off.

Others: When no one is using it, all the indicator lights will go out after a period of time, and the indicator lights will return to display when any function is used again.

Troubleshooting guide

Problem	Cause	Solution
No water from nozzle	Water supply hose is kinked	Straighten the hose to remove the kink
	Angle valve is off	Turn on the angle valve
	A water failure occurred	Restore the water supply
Poor water spraying	Water supply hose is kinked	Straighten the hose to remove the kink
	Angle valve is not fully turned on	Turn on the angle valve fully
	Filter is clogged	Clean the filter
Low water temperature	The water temperature is not set properly	Adjust the water temperature
Low seat temperature	The seat temperature is not set properly	Adjust the seat temperature
	In standby mode or energy saving mode	Switch to functional mode and wait for 3+ minutes
Low dryer temperature	The dryer temperature is not set properly	Adjust the dryer temperature
Dryer not blowing	In standby mode	Switch to functional mode to use dry function
Spray wand cannot retract	Power off	Push back the spray wand gently and put power on
	Get stuck by impurities	Remove the impurities
Spray wand cannot stretch out	Power off	Turn on the power
	User is not within the sensing area of the seat	Adjust position on seat to activate the sensor
Remote control cannot display	The positive and negative direction of the batteries is incorrect	Reload the batteries
	Low battery	Replace new batteries

Problem	Cause	Solution
Malfunction of deodorization	User is not within the sensing area of the seat	Adjust position on seat to activate the sensor
	Deodorization function continues after user leaves	It is normal for the deodorizing function to continue operating after user leaves, for complete odor removal
Foam shield has a small amount of foam	Foam agent run out	Add foam agent
After replacing the foam agent, the amount of foam produced by the foam shield is small	Air in the foam shield line after the foam agent has run out	Execute the "pumping" command to pump the foam agent into the foam shield
 Caution	If the problem cannot be resolved as per above solutions, please disconnect the power and contact service providers.	
	If the power leakage protection switch always trips, it means that the product is leaking. Please disconnect the power and contact service providers.	

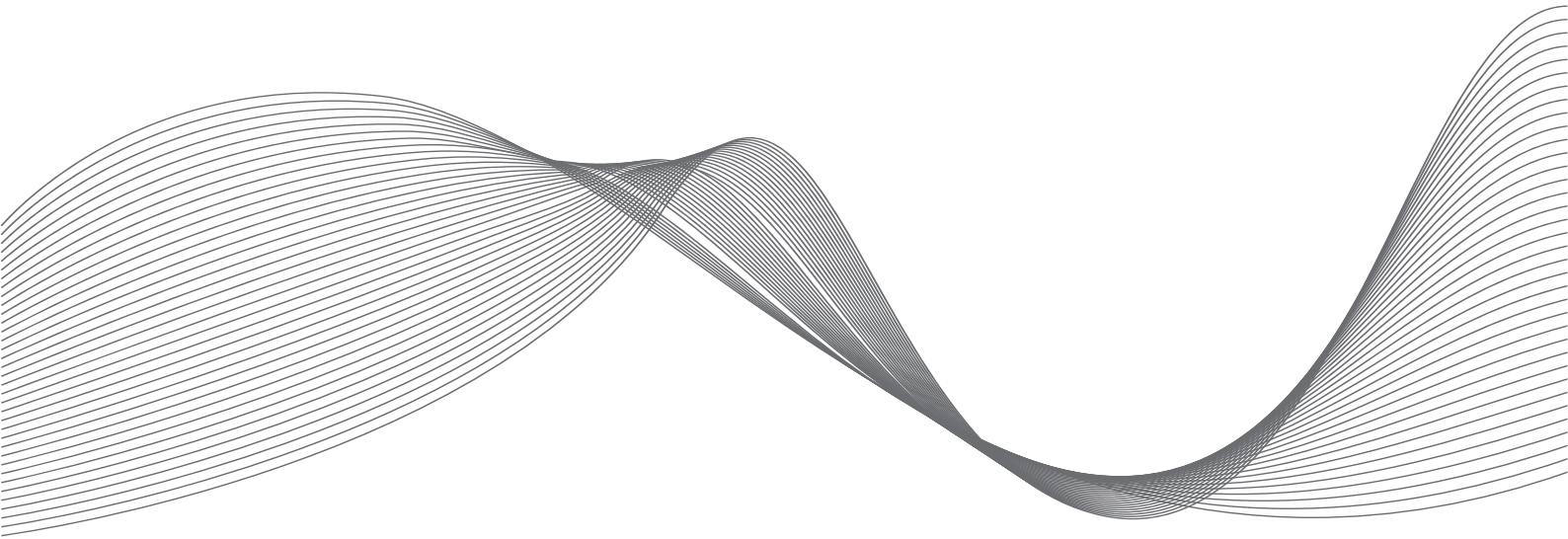

The picture of product may not be entirely consistent with actual appearance and color because of product improvements, please in kind prevail.